

## Swing aside double pivot extension CSN

### Specifications

- Screwed construction with aluminium bolster sides
- Hardened steel rollers on friction pads
- Retractable stopper provides a fall safety mechanism for the die
- Open / closed position locked
- Especially adapted for manual die positioning
- Manufactured to order with special dimensions

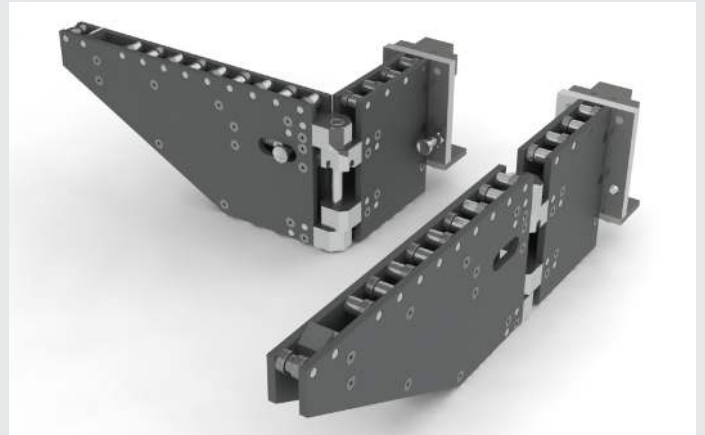

### Specifications and dimensions

	CSN 1000	CSN 3000
P (kg)	1000	3000
L	1000	1200
A	1060	1280
H	273	515
S	560	660
T	170	170
Ø D	30	40
N	16	19
E	60	60

P [kg]: Authorised dynamic load for a pair of extensions.

All dimensions are in millimeters.

Indexing of the extension in the open and closed position on each pivot.

If ball or roller bars are used, the layout heights (20, 65 and H on the attachment) are given relative to the tops of the balls or rollers in the raised position.

### Purchase order reference

CSN P (kg) - L (mm) - S ← special dimension  
 ↑ load      ↑ length

**Example** : CSN 1000- 1000

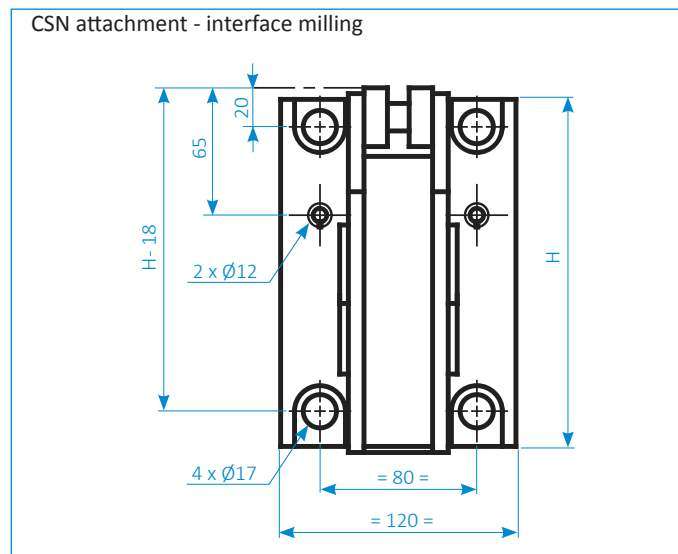
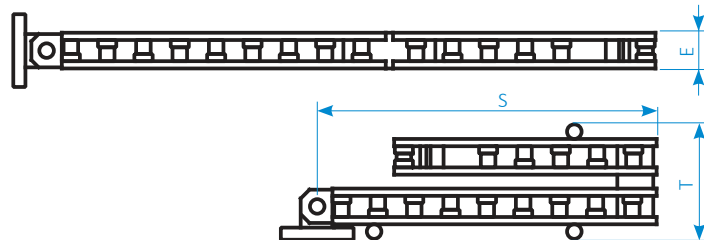
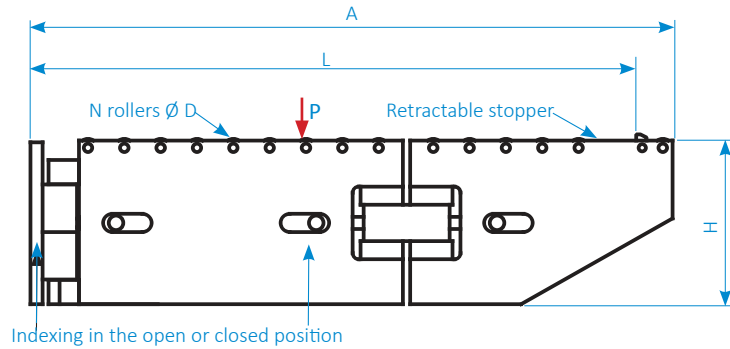

SERAPID France  
+33 (0)2 32 06 35 60  
info-fr@serapid.com

SERAPID Deutschland GmbH  
+49 (0)7931 96 47-0  
info-de@serapid.com

SERAPID Ltd  
+44 (0)1359 233335  
info-uk@serapid.com

SERAPID INC.  
+1 586 274 0774  
info-us@serapid.com