

Swing-aside bolster extension CSM

Specifications

- Screwed construction with aluminium bolster sides
- Hardened steel rollers on friction pads
- Retractable stopper provides a fall safety mechanism for the die
- Open / closed position locked
- Especially adapted for manual die positioning
- Manufactured to order with special dimensions

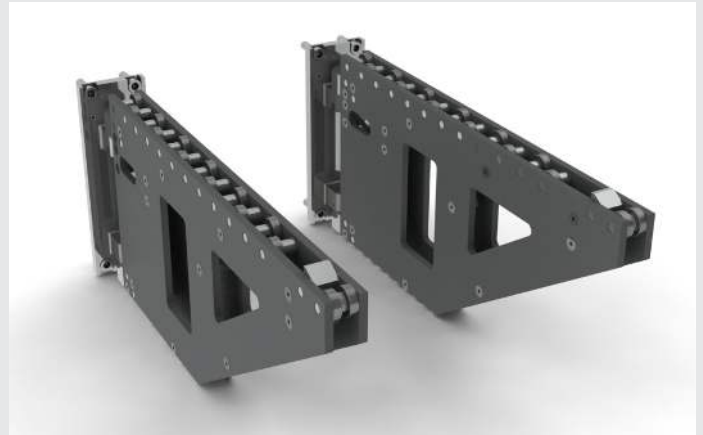

Specifications and dimensions

	CSM 1000	CSM 3000	
P (kg)	1000	3000	3000
L	500	800	1000
A	560	880	1080
H	183	375	475
Ø D	30	40	40
N	9	14	16
E	51	60	60

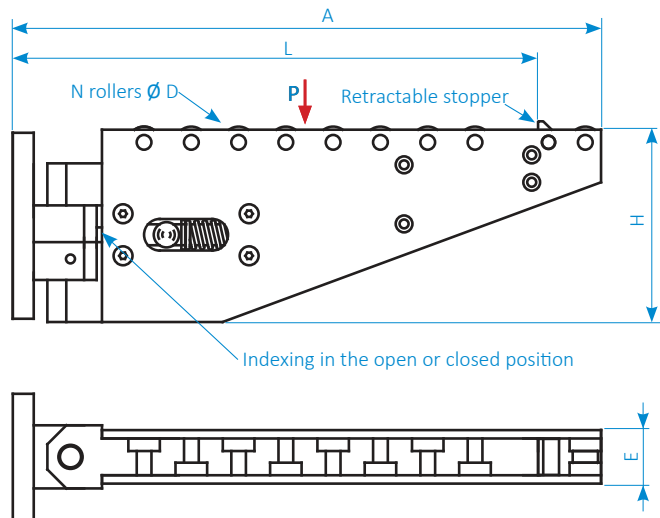

P [kg]: Authorised dynamic load for a pair of extensions.

All dimensions are in millimeters.

Indexing of the extension in the open and closed position.

If ball or roller bars are used, the layout heights (20, 65 and H on the attachment) are given relative to the tops of the balls or rollers in the raised position.

Purchase order reference

CSM P (kg) - L (mm) / assembly type - S ← special dimension
 ↑ load ↑ length ↑ see sheet 100-08 on the assembly types

Example : CSM 1000- 500 / 3

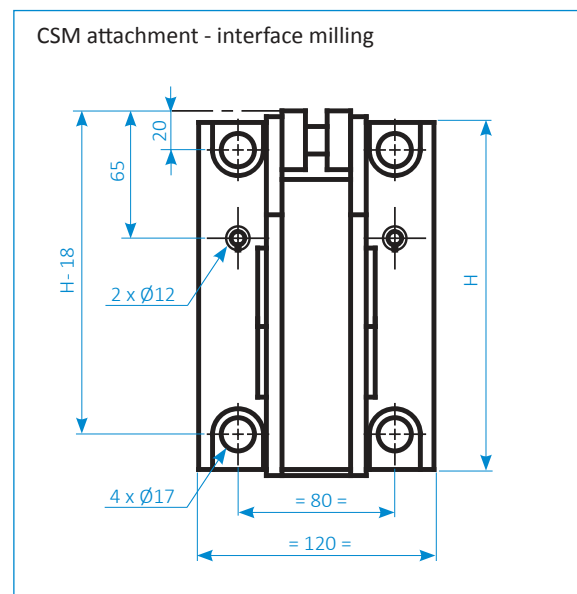

SERAPID France
+33 (0)2 32 06 35 60
info-fr@serapid.com

SERAPID Deutschland GmbH
+49 (0)7931 96 47-0
info-de@serapid.com

SERAPID Ltd
+44 (0)1359 233335
info-uk@serapid.com

SERAPID INC.
+1 586 274 0774
info-us@serapid.com