

Retractable roller cartridges CG / CGX

Specifications

- Used to create rolling surfaces of different sizes and shapes
- Built into the bolster, can be used when there is no available slot
- Adapted housing machined into the bolster or the sole of the die
- Uses spring washers
- Different sizes and capacities
- Specific sizes and shapes on request
- Standard working temperature of up to 70 °C, 160 °C with Viton seals

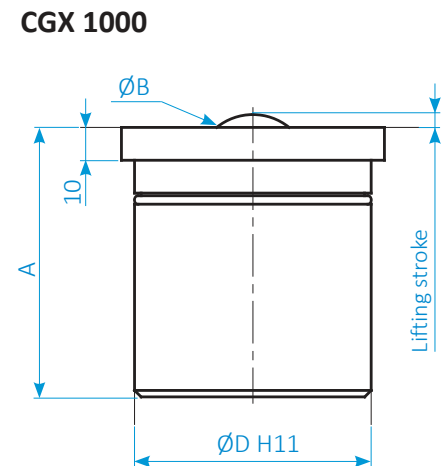
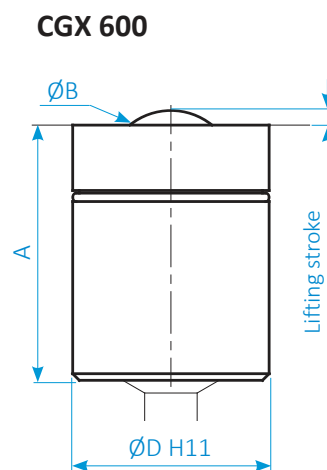
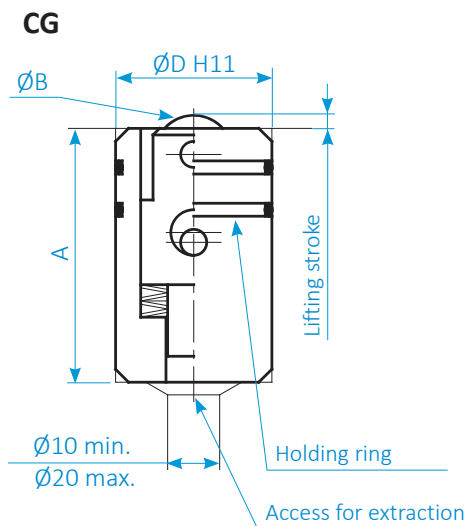

Specifications and dimensions

	CG 50	CG 100	CG 16-100	CG 20-160	CGX 600	CGX 1000
Force (kN)	0,5	1	1	1,6	6	10
A (mm)	40	40	50	55	86	82
Ø B (mm)	12	12	16	20	40	35
Stroke (mm)	1	1	2	2	4	4
Ø D (mm)	24	24	35	35	60	72

To calculate the allowable dynamic load for each roller, please refer to sheet 010-00.

All dimensions are in millimeters.



Locator stud on the top of the body to align during installation.

Purchase order references

CG 50 / CG 100
CG 16-100 / CG 20-160
CGX 600 / CGX 1000

SERAPID France
+33 (0)2 32 06 35 60
info-fr@serapid.com

SERAPID Deutschland GmbH
+49 (0)7931 96 47-0
info-de@serapid.com

SERAPID Ltd
+44 (0)1359 233335
info-uk@serapid.com

SERAPID INC.
+1 586 274 0774
info-us@serapid.com