

Heavy load hydraulic bar LPGH

for dies > 10 t

Specifications

- Very low rolling resistance
- Hydraulic lifting (the whole ramp is raised)
- Can be mounted upside down with the rollers towards the bottom, on the outgoing bolster
- Recommended for dies weighing > 10 t
- JIC (50 x 50 mm) or JIS (50 x 53 mm) standard slot
- Standard working temperature of up to 70 °C, 160 °C with Viton seals



Specifications and dimensions

	LPGH 600	LPGH 950	LPGH 1300
Length (L - mm)	600	950	1300
Lifting capacity (kN)	106	159	211
Static capacity (kN)	30	50	70
Max. working pressure (bar)	400	400	400
Number of pistons (M)	8	12	16
Max. oil volume (cm ³)	10	16	20
Max flow rate (l/mn)	2,1	3,2	4,2
Rollers (N)	6	10	14
Assembly distance (mm)	570	920	1270
Weight (kg)	10	15,5	21

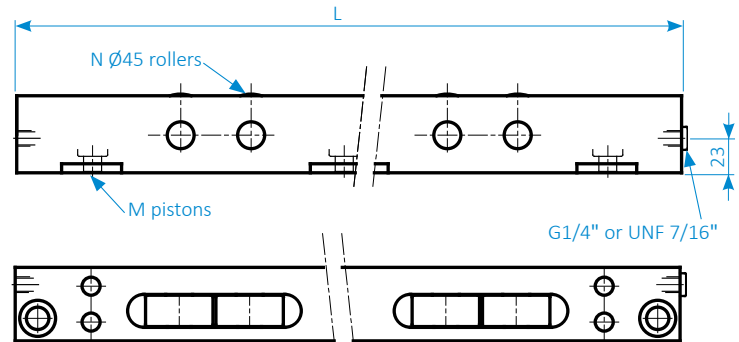

To calculate the dynamic load for each roller, please refer to sheet 010-00.

Rollers for transfer speeds > 100 mm/s on request.

In its standard version, the bar is sized for 50 x 53 mm slots. On request, the bar can be delivered for 50 x 50 slots. Please contact for other slot dimensions.

If no indication is given with the purchase order, we deliver G 1/4 hydraulic connectors, UNF 7/16 on request.

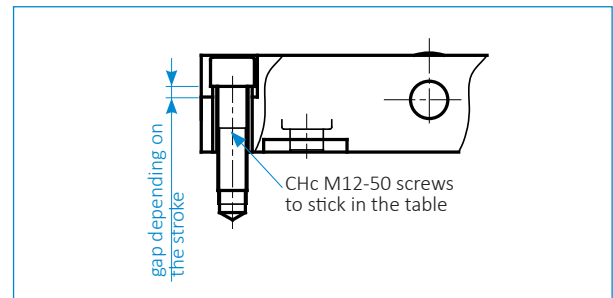

All dimensions are in millimeters.

Purchase order reference

LPGH - length **- Z - S**
 ↑ ↑ ↑
 for special T slot dimensions or
 bar lengths (attach a sketch)
 hydraulic connection
 standard or specific in mm

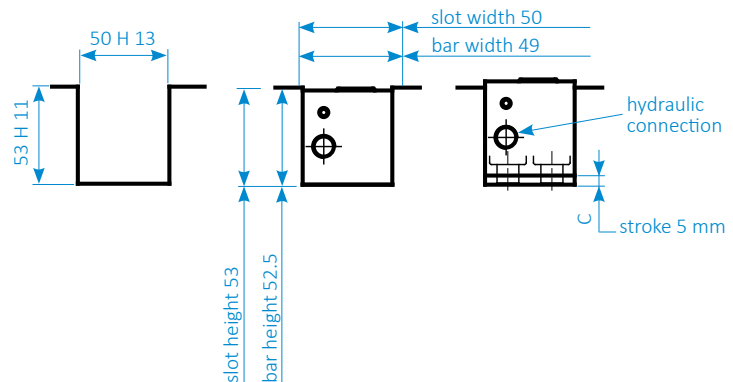

Indicate the hydraulic connection if it is not standard.

Examples : LPGH 950 G (standard model)
 LPGH 1000 UNF S (specific model)

SERAPID France - Head Office

ZI Louis Delaporte, Zone Bleue, Voie F
 F-76370 Rouxmesnil-Bouteilles | France
 +33 (0)2 32 06 35 60
 info-fr@serapid.com

SERAPID Ltd

Elm Farm Park, Great Green, Thurston,
 Bury St Edmunds | IP31 3SH England
 +44 (0)1359 233335
 info-uk@serapid.com

SERAPID Deutschland GmbH

Wilhelm-Frank-Straße 30
 D-97980 Bad Mergentheim | Germany
 +49 (0)7931 9647-0
 info-de@serapid.com

SERAPID USA INC.

34100 Mound Road
 Sterling Heights MI 48310 | USA
 +1 586 274 0774
 info-us@serapid.com

SERAPID Singapore Pte Ltd

1 George Street #10-01
 Singapore 049145 | Singapore
 +65 9119 5890
 info-sg@serapid.com