

## Hydraulic roller bars LGHL

### Specifications

- Single-direction movements
- Very low rolling resistance
- Hydraulic lifting
- When the die is clamped, the bar exerts no force on the sole
- Available for DIN 650 T slot sizes 22, 24, 28 and 36
- Manufactured to order, adaptable to your standard DIN 650 or special slots
- Can be combined in lines
- Standard working temperature of up to 70 °C, 160 °C with Viton seals

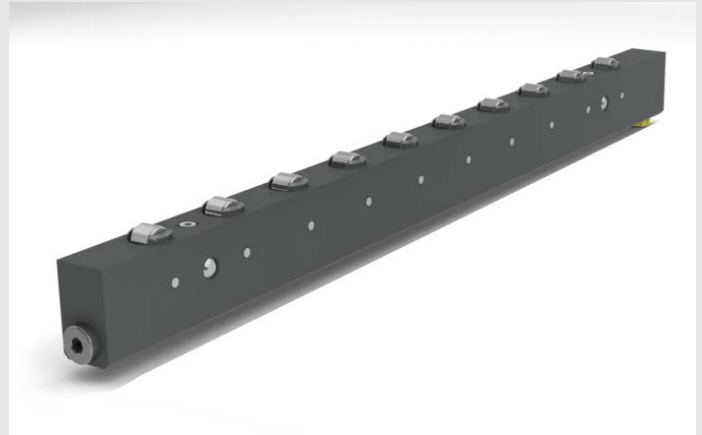

### Specifications and dimensions

		LGHL 22-24			LGHL 28			LGHL 36		
DIN slot		22/24			28			36		
Stroke (mm)		3			4			6		
N (rollers)		L(mm)	Fo(kN)	Vol*(cm <sup>3</sup> )	L(mm)	Fo(kN)	Vol*(cm <sup>3</sup> )	L(mm)	Fo(kN)	Vol*(cm <sup>3</sup> )
6		270	12	3,6	320	18,8	7,6	380	42	16,3
8		350	16	4,8	420	25,1	10,1	500	56	21,8
10		430	20	6	520	31,4	12,6	620	70	27,1
12		510	24	7,2	620	37,7	15,1	740	84	32,6
16		670	32	9,7	820	50,25	20,1	980	112	43,4
20		830	40	12,1	1020	62,8	25,1	1220	140	54,3
24		990	48	14,5	1220	75,35	30,2	1460	168	65,1
29		-	-	-	1470	91,05	36,5	-	-	-
30		1230	60	18,1	-	-	-	-	-	-
36		1470	72	21,8	-	-	-	-	-	-

\*Vol: max. oil volume Fo : at 0.5 mm above the table  
 Pressure: 100 bars. A pressure limiter set to less than 150 bars is imperative.  
 To calculate the dynamic load for each roller, please refer to sheet 010-00.

### DIN 650 T slot

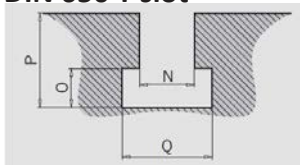

N	18	22	24	28	36
O	12	16	18	20	25
P	30	38	42	48	60
Q	30	37	42	46	56

Check the standard or special T slot dimensions before placing the purchase order. Specific dimensions on request.

### Purchase order reference

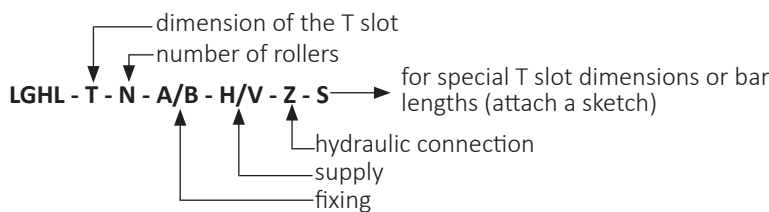

**Examples:** LGHL 28-10 BH G (standard model)  
 LGHL 28-10 AV UNF S (specific model)

### Supply options

G 1/8" or UNF 7/16"

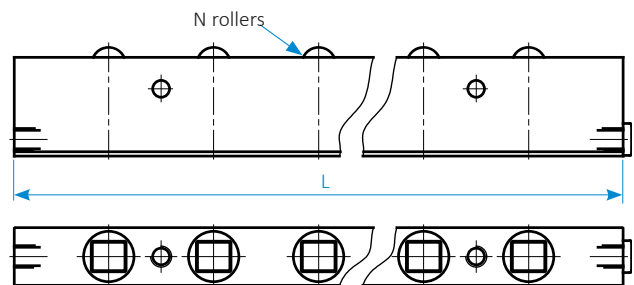
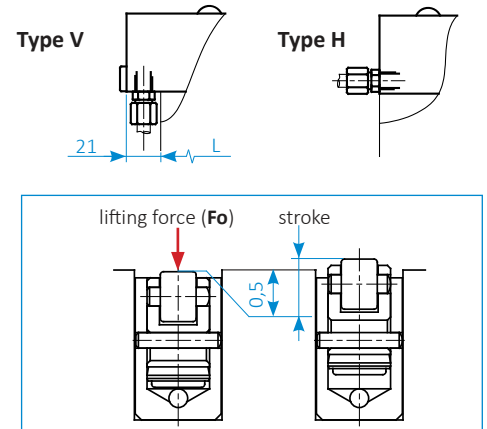

### Fixing options

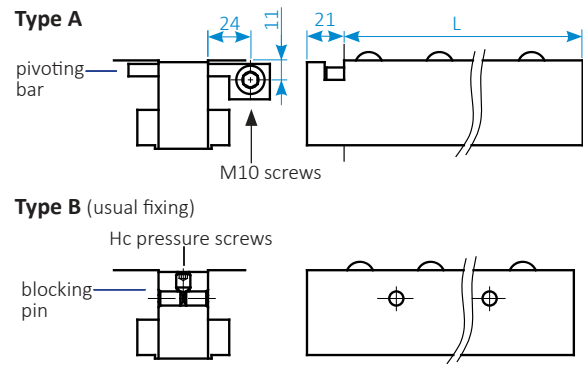

All dimensions are in millimeters.

#### SERAPID France - Head Office

ZI Louis Delaporte, Zone Bleue, Voie F  
 F-76370 Rouxmesnil-Bouteilles | France  
 +33 (0)2 32 06 35 60  
 info-fr@serapid.com

#### SERAPID Ltd

Elm Farm Park, Great Green, Thurston,  
 Bury St Edmunds | IP31 3SH England  
 +44 (0)1359 233335  
 info-uk@serapid.com

#### SERAPID Deutschland GmbH

Wilhelm-Frank-Straße 30  
 D-97980 Bad Mergentheim | Germany  
 +49 (0)7931 9647-0  
 info-de@serapid.com

#### SERAPID USA INC.

34100 Mound Road  
 Sterling Heights MI 48310 | USA  
 +1 586 274 0774  
 info-us@serapid.com

#### SERAPID Singapore Pte Ltd

1 George Street #10-01  
 Singapore 049145 | Singapore  
 +65 9119 5890  
 info-sg@serapid.com