

## Mechanical roller bar LGRL

### Specifications

- Single-direction movements
- Very low rolling resistance
- Mechanical spring lifting
- When the die is clamped, the rollers retract
- Available for DIN 650 T slots sizes 22, 24, 28 and 36
- Manufactured to order, adaptable to standard DIN 650 or special slots
- Can be combined in lines
- Standard working temperature of up to 70 °C, 160 °C with Viton seals

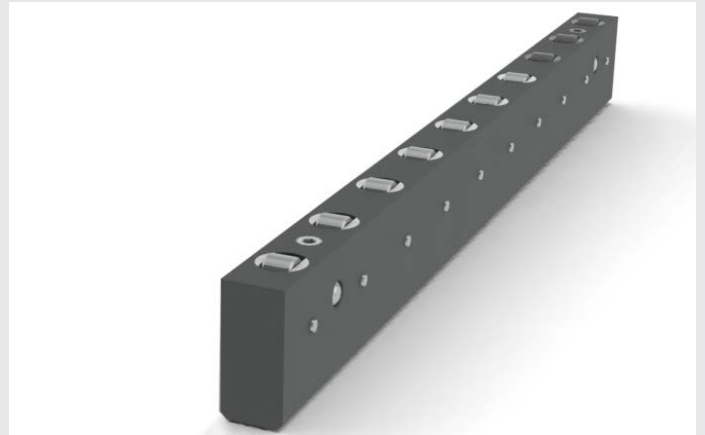

### Specifications and dimensions

	LGRL 22/24		LGRL 28		LGRL 36	
DIN slot stroke (mm)	22/24		28		36	
	2		4		4	
N (rollers)	L(mm)	Fo(kN)	L(mm)	Fo(kN)	L(mm)	Fo(kN)
3	120	1,95	150	3	180	4,8
4	160	2,6	200	4	240	6,4
5	200	3,25	250	5	300	8
6	240	3,9	300	6	360	9,6
8	320	5,2	400	8	480	12,8
10	400	6,5	500	10	600	16
12	480	7,8	600	12	720	19,2

To calculate the allowable dynamic load, please refer to sheet 010-00.

Fo : at 0.5 mm above the table

### DIN 650 T slot

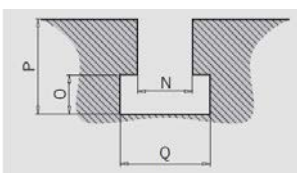

N	18	22	24	28	36
O	12	16	18	20	25
P	30	38	42	48	60
Q	30	37	42	46	56

Check the standard or special T slot dimensions before placing the purchase order. Specific dimensions on request.

### Purchase order reference

#### LGRL - T - N - S

- ↑ for special T slot dimensions or bar lengths (attach a sketch)
- ↑ number of rollers
- ↑ dimension of the T slot

Examples : LGRL 28-10 (standard model)

LGRL 28-10 S (specific model)

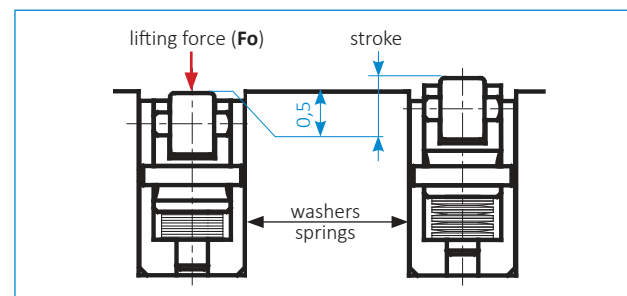
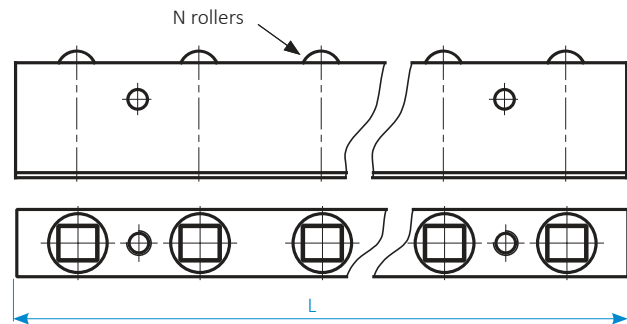

### Fixing options

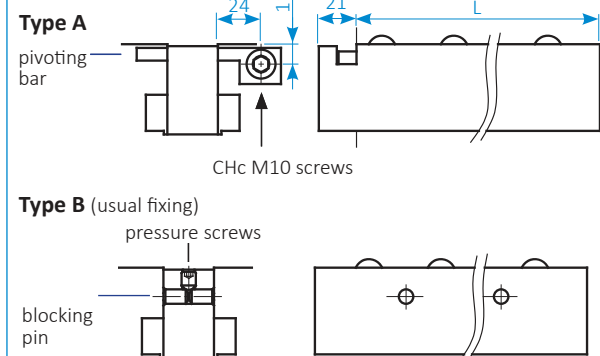

All dimensions are in millimeters.

#### SERAPID France - Head Office

ZI Louis Delaporte, Zone Bleue, Voie F  
F-76370 Rouxmesnil-Bouteilles | France  
+33 (0)2 32 06 35 60  
info-fr@serapid.com

#### SERAPID Ltd

Elm Farm Park, Great Green, Thurston,  
Bury St Edmunds | IP31 3SH England  
+44 (0)1359 233335  
info-uk@serapid.com

#### SERAPID Deutschland GmbH

Wilhelm-Frank-Straße 30  
D-97980 Bad Mergentheim | Germany  
+49 (0)7931 9647-0  
info-de@serapid.com

#### SERAPID USA INC.

34100 Mound Road  
Sterling Heights MI 48310 | USA  
+1 586 274 0774  
info-us@serapid.com

#### SERAPID Singapore Pte Ltd

1 George Street #10-01  
Singapore 049145 | Singapore  
+65 9119 5890  
info-sg@serapid.com